



The Wing Nut

A Quarterly Publication of the Arizona Radio Control Society Inc.



OnLine at WWW.ARCS1.COM

September/October 2007

2007 CAMAC CALENDAR OF EVENT INFORMATION FOR FLYING SITE LOCATIONS & HOST CLUB CONTACTS

SOARING CONTEST	COLDWATER PARK	CASL	SEPT 8
FALL KICK OFF (free flight)	ELOY	PMAC	SEPT 15
KARL MARSCHINKE MEMORIAL	TUCSON C. COLUMBUS PARK	CACLC	SEPT 22,23
TUCSON AEROBATIC SHOOT OUT	TUCSON MODELPLEX PARK	TIMPA	OCT 3,4,5,6,7
FALL ELEC. AIRCRAFT RENDEVOUS	MUSTANG FIELD	ARCS & KFERC	OCT 5,6,7
AMA FALL AUCTION	VIEWPOINT COUNTRY CLUB	AMA	OCT 20 (8:00 AM)
1/8 AIR FORCE SCALE FLY-IN	ADOBE MOUNTAIN PARK	1/8 AF	OCT 20,21
GHOST RIDERS (free flight)	ELOY	PMAC	OCT 21
CARRIER PLUS X	AVONDALE FRIENDSHIP PARK	CACLC	OCT 27,28

FLYING SITE LOCATIONS

- Adobe Mtn. Park is south of the Water Park on 43rd Ave. & Pinnacle Peak Rd.;
 Avondale Friendship Park (control line only) is on McDowell Rd between 115th Ave. & Dysart,
 Cave Buttes Park is just west of Cave Creek Rd & Jomax Rd;
 Coldwater Park is ¼ mile east of the intersection of Dysart and Riley in Avondale (gliders only);
 Estaban Park (control line only) is at 36th St & Roeser,
 Mustang Field is approx 7 miles west of Grand Ave on Bell Rd, turn left (south) after crossing
 McMicken dam, go 1.2 miles to Bell Rd and left again to entree sign;
 Rodeo Park is at Ray Rd. & Val Vista (gliders only);
 Superstition Air Park is entered ½ mile north of Brown Rd on Meridian Rd.
 (1 mile east of Signal Butte Rd);
 Superstition Field is just off Ironwood Rd 3.25 miles south of Baseline Rd;
 Speed World is 7 miles northwest of Bell Rd on Grand Ave to Happy Valley Rd., then turn
 Left and go west to sign entrance.

Current Officers—Club Contact Information

President

Jack Knuth (623) 878-9140 jaknuth@cox.net

Vice President

Position Available

Treasurer

Jeff Lambert (623) 544-9224 jeff5403@cox.net

Secretary

Dick Olin (623) 214-1439 rolin2@cox.net

Field Marshall

Juan Loyola (623) 936-3077 jloyola@walshbros.co

Safety Officer

Arnold Alpert (623) 594-2758 arnie689@cox.net

Newsletter Editor

Frank Mattox (623) 932-5922 fmattox@intouchmail.net

Scheduled Events

The next meeting will be at 6:30 PM, September 12, 2007, at the Peoria Community Center.

See map on page 15.

A reminder that the next events at the field are the F.E.A.R. electric fly on October 5th, 6th, and 7th, and the November Nonsense club fly.

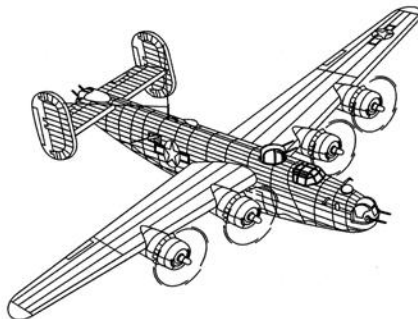

lost in - or is it into - the desert

By Otis Hammonds

it was on Wednesday 06-20-07 after most on the normal morning flyers had departed for the day; those remaining at the field were only four. These four consisted of Bob Lange, Chuck Watson, Mike Thomson, and me.

I decided I would make one more flight planning to drop two more bays of balls as we had been doing on most flights that day.

That is the current or latest 'thing' at Mustang Field, at least for part of the Monday, Wednesday, Friday bunch. One cannot believe the 'load of garbage' (parachutes, balls, balls with stringers, playing cards, cat food cans, water balloons or whatever comes to mind) that can be put aboard the Kadet Seniors, especially when the push rods for the rudder and elevator are removed from the fuselage (servo mounted to the far aft).

Not to be out done, Bob, as well as Mike decided they too would put in at least one more flight...Chuck opted not to go up again that day.

The three of us were in the air, and I made a drop pass, opening the first 'bomb-bay' door. Apparently, I had put too much on board, or one or more of the stringers (on the balls) became entangled on something in the aircraft or on the door as nothing came out...Maneuvering with abrupt pull-ups, rapid power and speed changes did not seem to help as the load still failed to 'dump.' Making a circle, some balls suddenly started out (at a most inoperative time, as the plane was some considerable distance away and almost over the berm). The front bay emptied, but the rear still failed to dump. While in the process of repeating the maneuvers of before (never at a high speed), my plane started fluttering and then a loss of control followed. The Kadet, while at a reasonable altitude had turned coming directly toward the flight line, on more or less a south heading.

Shouting out a warning that the plane was headed toward us with no control (the no control bit; not that much out of the ordinary for most of my flights but usually I can at least keep it north of the runway)

lost in-or is it into-the desert, continued passing to the south of the runway directly into the sun, at which time I loss sight of it (and everything else, for that matter, for a short bit). It was about this time, we heard a loud 'pop' and Chuck called out that I had just lost an aileron (before you jump to conclusions, there was traces of wood on the CA hinges) that had been hanging down vertical from one end.

Calling out that I had loss my plane, Bob (even though he was flying) being the helpful individual he is (also just plain nosey) turned and looked for mine, then turn back to his, then back somewhere toward the south. After what seemed to me as an insurmountable amount of time, Bob said, "There it is." "*There where, Bob, I can't find it?*" I answered back. About this time, Bob shouted "Pull up, pull up, Otis."

A few months after moving to Nome, AK and working for Munz Northern Airlines, I had an emergency landing (one of several, throughout the years) with a SR-9 Reliant Stinson Gull Wing on the tundra. Shortly thereafter, I became known as 'Captain Lucky.' All the years afterwards, when flying in Alaska, the name stuck.

Well, I certainly lived up to that name that Wednesday morning; I caught sight of the plane just as I added up elevator, and it was in a steep bank, nose pointed down steeply and only a few feet above the parking lot. How I (or did the craft do it all on its own, as I much suspect) recovered I will never know, we all thought it was a goner. At any rate as I gained height my tired old brain was starting to catch up with the situation (somewhat) and begin banking with the ruder. Being the prudent coward that I am, and with Chuck standing next to me, I handed him my transmitter while saying, "Here Chuck, you have a much better chance of getting this on the ground in one peace than I do." He did get it down and in one peace; however he too had some difficulty with controlling it. The horn on the remaining aileron turned out to be very loose, ineffective and almost totally detached.

As Chuck was landing my ship, Bob said to all "I lost my plane, the last time I looked back, I could not find it." At this,

lost in-or is it into-the desert, continued

I began searching for it, as did Chuck as soon as he had mine on the ground.

Bob and Chuck started walking west, and as soon as Mike landed, we moved our planes and gear into the shade, and he and I took my pickup truck and drove out to where they were.

The four of us looked, with the truck and walking the best part of two and half hours, with no result, with no result that is other than creating a slow leak in the sidewall from a stub end of a very small limb on the front tire of the truck. The discovery of the leak was not until the next morning, resulting it turns out, with a necessary new tire replacement.

With a meeting set for around 6:00 – 6:30 A.M., we resumed our search, along with Jack Brown who volunteered his assistance in our quest of the Kadet. Again, we use the pickup, but this time it was decided to stay on the existing roads (there are many of them out there). Drive a bit, walk, then back to the truck and move a little ways...an hour or so later, upon returning to the vehicle we discovered the tire to be very low. It was time to put the spare on (none of us wanted to undertake that little chore) or rapidly depart for a service station for a re-inflation, which was the option chosen (tire replacement, instead of just air). I left, while the others searched another couple of hours, all to no avail.

Friday morning was a repeat of the previous days, still not finding the Kadet.

Bob and Mike, again looked for about 3½ hours on Saturday (Chuck and Otis had prior comments [wife of both involved; no way of getting out of it]).

Mike made a trip out to Pleasant Valley Airport (glider operations just south of Lake Pleasant) where he attempted arrangements for an aerial search; this too went by the wayside. He stopped at Duncan's R/C on his way home, telling about the search; next thing, a RC pilot with a video camera on a Slow Stick (of all things) and lap top computer was hired for a search. He would be out the following Saturday.

lost in-or is it into-the desert, continued

Bob and Mike met him, along with a PC operator friend of his at the field. Pictures on the PC were lost at about the time of takeoff; the stick crashed just west of the berm; another search for missing AC ensued. Stick found, peaces picked up, and plans to return the following Saturday morning for another attempt.

Bob at the airport at the appointed time; no pilot. Bob shot the breeze (he is good at that) with some of the heilo drivers for quite a while. Three hours later, still with no pilot showing, Bob went home, somewhat heated, one might even say 'steamed.' It turns out, or at least he (the Stick pilot) said he was ill.

We three (Bob, Chuck, and me) went out again Monday (7-2-07) for just over an hour and a half. Still no Kadet.

Received below E-mail from Bob Wednesday, July 04, 2007 1:27 PM:

.....Got a phone call last night from the flying fotog.....said he would be out there at 7 this AM.....so went out there at 6 or so.....he showed about an hour late....(8). I know you're excited so here it is....only pics we got was a few he clicked on the way out to the runway....he took off climbed to 150' rolled over & went in....same as before.....this time destroyed the plane. He said he got hit....but I'm convinced it is a range thing”.

Well, here you have it, one lost Kadet, one totaled Slow Stick, one replaced truck tire and after many hours of wakening (more than I have walked in total for the last 6 months, I venture a guess), part of which was in 100+° F temperatures.

Where is the Kadet? In the desert or *into* the desert (*did it bury itself*)? The mystery remains.

Otis

See page 17 for an update

Polk Hobbies Tracker III update.

As several of you know, I bought the Tracker III with the Seeker II receiver from Polk Hobbies in Late 2005.

It worked for a year without problems, then started to act up. Wouldn't pass a range check, and the built in scanner would tell me that there was a signal on several of the channels that I had it set up on.

I sent it back to Polk for repair and it came back a few weeks later with "Updated Software"(v1.37.5), A new gimbal, and a new transmitter module. It still wouldn't pass a range check, plus the program instructions didn't match anymore.

Sent it back again with the list of problems.

Back it came with an even newer set of software (v1.38). The programming instructions were still off some from the list, but it at least passed a range check this time. I Installed it into my U-Can-Do-3D. It went out and up a few hundred feet and then acted like (according to observers) it had lost the signal. Scratch one UCD 3D. Foolishly, I also put up my Sportster EP (different receiver, a Polk Seeker 6) that same day with the same result. A crash. Same problem, it acted like it ran out of signal.

Sent the radio back to Polk again.

It was returned a couple of weeks later with another transmitter module according to the repair ticket. Now Ch. #1 and Ch. #2 worked together (Elev & Ailerons worked on the elev. stick)

This time I called the service dept. and was walked through another menu system that was used to check function and centering.

At the end of this they suggested that I send it in again.

I told them that it was time for them to pay the shipping both ways, and they sent a prepaid shipping label. Back it came a week or two later with another transmitter module. This time we were back to square one in that it wouldn't pass a range check again.

I called John Gill this time, mentioned the history of the unit, and suggested that we go to square one and that they send me a new radio. He agreed and again I shipped it back with the understanding that they were out of stock at this time and it would take a few weeks before they could send out another one.

About a week later, Mary from Polk called with the news that they were refunding my purchase price. That was satisfactory with me and after a few days, my refund showed up on my credit card.

Bottom Line: would I buy another Polk Radio when they got the new stock. Not NO but H--- NO. Was I happy with the service dept at Polk. Same Answer.

Was I happy that they decided to refund my money. In a word YES. I think that I'll start looking at Spread Spectrum Technology.

Frank Mattox

Pull out and hang on refrigerator as a reminder after filling out and mailing entry.

FALL ELECTRIC AIRCRAFT RENDEZVOUS 2007

Presented by:
KNIGHT FLYERS & ARCS



WHEN:
OCTOBER 5, 6 & 7, 2007
FRIDAY, SATURDAY and SUNDAY

Visit our website for the latest list of Sponsors and Vendors that will be at FEAR 2007!
www.knightflyersaz.com

WHERE:
ARCS - MUSTANG FIELD SURPRISE, AZ

WHAT:
ELECTRIC POWERED AIRCRAFT AND HELI'S

Event restricted to electric powered models. Fee is \$15/day or \$25 for three days if you Pre-Register before September 20, 2007. Add \$5 after September 20. Current AMA Required! Remember to bring your AMA card to the event, you must show your card to be able to fly. As always - spectators are welcome.

Pilot Raffle, Awards for Best Mono Plane, Multi Wing, Jet, Military, Heli, Peoples Choice, Pilots Choice, CD's Choice, and more

Visit www.knightflyersaz.com for additional event information and updates. Vendors of electric model stuff are welcome! Vendor space is limited, see the website for vendor/sponsor information.

Onsite camping available, no hookups.

FEAR 2007 - PILOT REGISTRATION FORM

Pre-registration thru September 20, 2007: \$15 one day or \$25 for two-three days. Additional \$5 after Sept 20. Make check or money order out to ARCS and Mail to:
Knight Flyers, PO Box 5090, Peoria, AZ 85385

Name: _____ Camping Onsite? Y N

Address: _____ Email: _____

City: _____ State: _____ Zip: _____

AMA#: _____ # of Models: _____ Chan: _____

Proof of AMA membership is required at the event in order to be able to fly. Please observe AMA, ARCS field and event rules. We are looking forward to seeing everyone at the event.

SURFACE

R5 - A racing plug so durable it can survive leaner needle settings and high-nitro/high-rpm 1/8 scale racing. (OSMG2694)

A5 - Slightly "cooler" than the #8, and ideal for the constant "on/off" throttle action in 1/10 and 1/8 scale racing. (OSMG2693)

P-7 - An all-season, medium-heat plug for Turbo head engines. (OSMG2695)

#8 - A medium-hot plug for 1/8 scale racing and most .12-.21 car, boat and truck engines. (OSMG2691)

P-6 - A hot choice for all .12-.21 Turbo head engines. (OSMG2696)

LC3 - A long-reach hot plug created for the Traxxas® TRX 2.5 (.15) Racing Engine and other 1/10 scale off-road engines. (OSMG2700)

P8 - Cold enough to outlast the hottest "heats". For Turbo head engines. (OSMG2696)

AIR

F - The plug for all O.S. multi-cylinder and 4-stroke engines. Long reach — long life. (OSMG2692)

A5 - A medium-cold plug ideal for engines .60 and larger. (OSMG2693)

#8 - A medium-hot plug suitable for most 2-stroke flight engines. A flier favorite! (OSMG2691)

A3 - A long-lasting hot plug for most 2-strokes up to .60. (OSMG2690)

P-3 - An ultra-hot plug for the 18T2 and other Turbo head engines. (OSMG2699)

A3 - A hot plug with the longest life and lowest cost of any O.S. sport plug. Great for beginners and .12-.15 engine break-in. (OSMG2690)



Here's a little chart That might come in handy The next time your in the Market for some Glow Plugs





CHINO VALLEY MODEL AVIATORS



THE STEVE CROWE WWII EAGLE SQUADRON FUN FLY Saturday & Sunday Sept. 22 & 23, 2007

FIELD IS 2.9 MILES DOWN PERKINSVILLE ROAD FROM HWY 89 IN CHINO VALLEY



Eagle Squadron in 1943

Steve and a Spitfire with his squadron Call sign



Tail Gate Swap

Number 133 Squadron was formed on August 1, 1941 at Coltishall, England and assigned the squadron code MD. On August 16 the squadron moved to Duxford, England where it was brought up to operational strength flying Hurricanes. They met the Germans in combat on April 26, 1942 and got their first kill a FW-190. They received the new Spitfire VBs in February of 1942. More information can be found at www.fourthfighergroup.com/eagles/133.html

We as a country owe a great deal to men like Steve, our freedoms we often take for granted, thanks Steve.

**Bring Your RC
"Junk"
It can be
Another's
Treasure**

Pilot's Fee will be \$5.00. This is a Fun Fly to honor our WWII Eagle Squadron member Steve Crowe who flew Hurricanes and Spitfires during WWII during the Battle of Britain. Steve has 4 confirmed kills and had tea with the queen among his many adventures. Come meet Steve and bring an airplane, any powered airplane, fly, socialize, talk RC with other area pilots, check out the swap meet and enter to win a raffle prize.

Our Raffle Master Steve Kile will have a great Pilot's Raffle prize for the event and some general raffle prizes for non flyers.

**Here's something to do on a hot valley day, go north.
Have fun at a combo Fun Fly & Swap Meet.**

Minutes
ARCS Business Meeting, May 9, 2007
Peoria Community Center

Meeting called to order at 6:30 PM by President Jack Knuth, 8 members present.

Motion to approve February Meeting Minutes as published in the Wing Nut, carried.

The first quarter 2007 budget summation was presented and approved. The lease payment for 2007 has been made. Taxes will be paid when an invoice is received.

Jack Knuth gave an update on the possible effect of the power line on the field:

The approximate boundary lines for the field are the end of the runway at the east side and just inside the berm (drainage ditch) at the west side.

The power line will most likely be located on the State property to the west side of the field. Depending on the final location, there may still be distance enough to permit flying from the present runway.

A best guess would be for surveys to start this year, with actual construction beginning during 2009. (Members need to be aware that workers may soon be present in the area and that it serves our cause to extend them every courtesy).

Jack will initiate discussion with the Water Department to explore options to provide weekend access to the field through their gate.

A reminder that the next events at the field are the F.E.A.R. electric fly on October 5th, 6th, and 7th, and the November Nonsense club fly.

Cont. on Page 16

The Club received a DVD from Hanger-9 describing their new PTS (Progressive Training System) that combines a trainer and sport flyer in the same plane. For training, “droop wing extensions” are added to provide the required stability. Two versions are available; F-22 Raptor and P-51 Mustang. The DVD is available from Dick Olin, or the planes can be reviewed at

www.hangar-9.com/PTS/

The next meeting will be at 6:30 PM, September 12, 2007, at the Peoria Community Center.

Motion to Adjourn, seconded, carried.

Submitted by: Dick Olin - Secretary



At the Arizona Radio Control Society, we Try to publish something for everyone. Since there will always be mistakes in this type of publication, and people enjoy looking, Happy Hunting

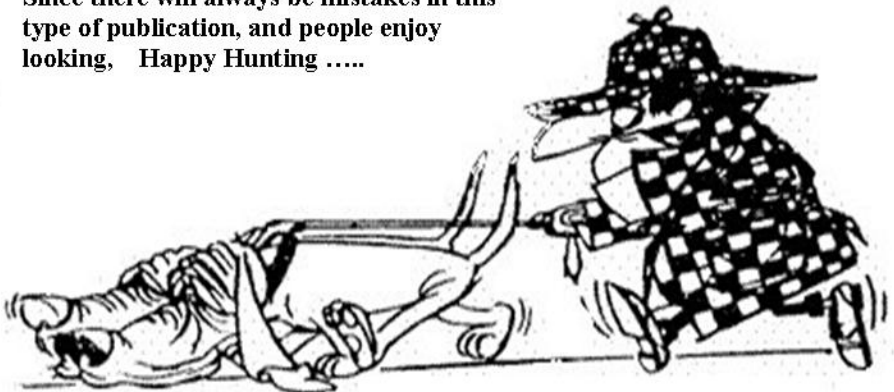

In an E-Mail dated Aug 6th

As of 1:30 PM this afternoon possession of BLUE COW 6 was regained. The airplane is now back in my possession. It was found just outside the fence to the south of the field. Not much farther than the berm. The prop was not broken, but the nose wheel was pushed back but no damage to the firewall. The fin & rudder is broken loose & laid over, the wing plastic screws broke & pretty much saved the wing & fuse. The parachutes were still inside. The engine looks OK, the plane was sitting upright on the gear. Some tears in the covering, but it is really faded, the blue in places is almost clear. The guy that found it was sitting on top of the earthdam at sunrise with his binoculars..... said he saw it glisten in the sun as the sun came up & went over to see what it was. He left a note on the gate with his phone number. Thought you might be interested.....

Bob Lange.....

PS he said he looked for a name & phone # on the plane but there wasn't one. Guess what....there is one on all my planes now.....



" PERHAPS WE COULD LOOK AT THIS AS A CHEMICAL REACTION THAT OCCURS WHEN DIRT AND WOOD COME INTO CONTACT WITHOUT THE PRESENCE OF AIR!"

Arizona Trivia

Weird Place Names

The month of July brings out the stars and stripes, and one place in Arizona owes its name to Old Glory. Although Arizona didn't officially become a state until 1912, the Territory showed its patriotism, especially during Fourth of July celebrations. In July 1876, a group of settlers traveled through northern Arizona near a spot that had become known as Old Town Spring. The date was July 4 and, wanting to celebrate the nation's centennial, one of the group's members climbed a pine tree, stripped it of its branches and raised a United States flag there, attaching it with rawhide straps. The flagpole could be seen for miles and, for years, was used by pioneers traveling west as a trail marker along Beale Wagon Road. When the settlement became official with the establishment of a post office in 1881, the residents decided on a most appropriate name and the town of Flagstaff was born.

Dehydrated River Foiled Escape

In 1944, a group of German prisoners of war being held at a compound in central Arizona, not far from the Salt River, devised a plan of escape. Three of the men built a small boat and mapped a course that would take them from the Salt River to the Gila River, and eventually to the Colorado River and freedom in Mexico. Together, they tunneled out of the compound and carried their makeshift boat to the river.

But, shortly after, they were captured, sitting in their boat in the dry riverbed waiting for the water to rise.

In Germany, those three men are still known as the "Crazy Boatmen of Arizona."

ARCS Field Location

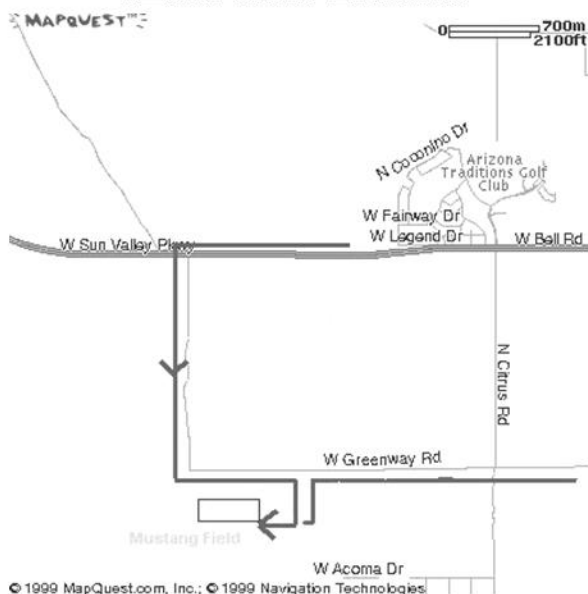

Staff/Business & Club Meeting Location

